





# Resistance thermometer

# NL-Cryo



## Multi-spot sensor for cryogenic use -200°C to +95°C

- I Type NL-cryo is a multi-spot thermometer for measurement of average temperatures, primarily in stationary tank systems, with requirements to the tolerance and the response time of the temperature measurement. Type NL-cryo is often used in connection with measuring of volume in e.g. gas / LNG.
- I The measuring elements are according to EN 60751. Max. 20 elements per sensor. Min. 150 mm from bottom of the sensor to the first spot.
- I Flex tube of stainless steel, standard 1" or ¾".
- I Accessories: Terminal boxes and transmitters (see separate data sheet)
- I Technical information regarding material and connection diagrams: see separate data sheet.
- I Approvals: ATEX, German PTB  
FM08ATEX0060X  
CE0359  II 1G   
Ex ia IIC T5
- I Tube filled is with dry Argon gas from the factory to prevent condensation of water inside the sensor.

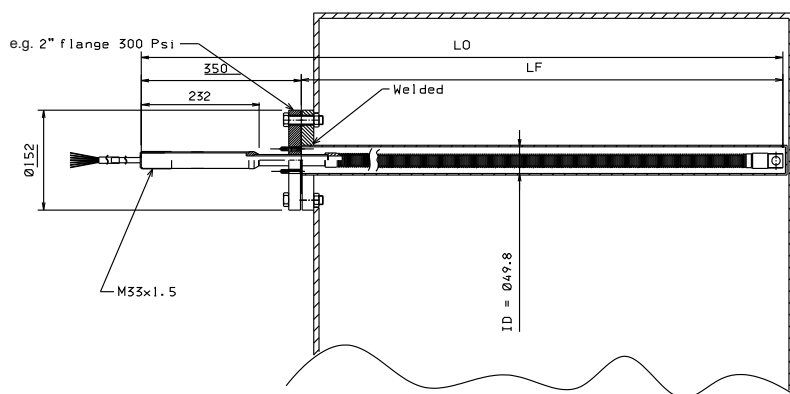

Ordering: See installation on back page



# ORDERING FORM / RESISTANCE THERMOMETER NL-Cryo

V3.3

**Type NL-Cryo** .....

<p><b>Overall length./LF</b> Min. 950/ max. 100000 mm .....</p> <p><b>Sheath dia.</b> 1" ..... 3/4" .....</p> <p><b>Connection - M33x1,5 - Flange Type</b></p> <table border="0"> <tr><td>1 1/2" ANSI 150 psi welded .....</td><td>61</td></tr> <tr><td>2" ANSI 150 psi welded .....</td><td>62</td></tr> <tr><td>3" ANSI 150 psi welded .....</td><td>63</td></tr> <tr><td>4" ANSI 150 psi welded .....</td><td>64</td></tr> <tr><td>6" ANSI 150 psi welded .....</td><td>65</td></tr> <tr><td>8" ANSI 150 psi welded .....</td><td>66</td></tr> <tr><td>10" ANSI 150 psi welded .....</td><td>67</td></tr> <tr><td>1 1/2" ANSI 300 psi welded .....</td><td>71</td></tr> <tr><td>2" ANSI 300 psi welded .....</td><td>72</td></tr> <tr><td>3" ANSI 300 psi welded .....</td><td>73</td></tr> <tr><td>4" ANSI 300 psi welded .....</td><td>74</td></tr> <tr><td>6" ANSI 300 psi welded .....</td><td>75</td></tr> <tr><td>8" ANSI 300 psi welded .....</td><td>76</td></tr> <tr><td>10" ANSI 300 psi welded .....</td><td>77</td></tr> <tr><td>DN50 PN16 welded .....</td><td>81</td></tr> <tr><td>DN50 PN40 welded .....</td><td>82</td></tr> <tr><td>DN65 PN16 welded .....</td><td>83</td></tr> <tr><td>DN65 PN40 welded .....</td><td>84</td></tr> <tr><td>DN80 PN16 welded .....</td><td>85</td></tr> <tr><td>DN80 PN40 welded .....</td><td>86</td></tr> <tr><td>DN100 PN16 welded .....</td><td>87</td></tr> <tr><td>DN100 PN40 welded .....</td><td>88</td></tr> <tr><td>Other (special defined by customer) .....</td><td>00</td></tr> </table> <p><b>Number of conductors</b></p> <table border="0"> <tr><td>3 wire .....</td><td>3</td></tr> <tr><td>4 wire .....</td><td>4</td></tr> <tr><td>Common return .....</td><td>5</td></tr> <tr><td>Common return 50 ohm offset .....</td><td>6</td></tr> </table> <p><b>Number of spots</b> *) See spot limitations.....</p>	1 1/2" ANSI 150 psi welded .....	61	2" ANSI 150 psi welded .....	62	3" ANSI 150 psi welded .....	63	4" ANSI 150 psi welded .....	64	6" ANSI 150 psi welded .....	65	8" ANSI 150 psi welded .....	66	10" ANSI 150 psi welded .....	67	1 1/2" ANSI 300 psi welded .....	71	2" ANSI 300 psi welded .....	72	3" ANSI 300 psi welded .....	73	4" ANSI 300 psi welded .....	74	6" ANSI 300 psi welded .....	75	8" ANSI 300 psi welded .....	76	10" ANSI 300 psi welded .....	77	DN50 PN16 welded .....	81	DN50 PN40 welded .....	82	DN65 PN16 welded .....	83	DN65 PN40 welded .....	84	DN80 PN16 welded .....	85	DN80 PN40 welded .....	86	DN100 PN16 welded .....	87	DN100 PN40 welded .....	88	Other (special defined by customer) .....	00	3 wire .....	3	4 wire .....	4	Common return .....	5	Common return 50 ohm offset .....	6	<p><b>Placement of spots</b></p> <p><b>Cable lead-out - total length LK</b> Rose J-box w. M33×15 Optional length/mm - min. 500 - max. 26500</p> <p><b>Temperature range</b> ..... With drain nipple -200/+95°C ..... Without drain nipple -200/+95°C</p> <p><b>Tolerance class</b> ..... Cl. A EN 60751</p> <p><b>Sensing element</b> ..... 1×Pt-100</p>	<p style="text-align: right;">mm</p> <table border="1" style="width: 100%; border-collapse: collapse;"> <tr><td>1. spot</td></tr> <tr><td>2. spot</td></tr> <tr><td>3. spot</td></tr> <tr><td>4. spot</td></tr> <tr><td>5. spot</td></tr> <tr><td>6. spot</td></tr> <tr><td>7. spot</td></tr> <tr><td>8. spot</td></tr> <tr><td>9. spot</td></tr> <tr><td>10. spot</td></tr> <tr><td>11. spot</td></tr> <tr><td>12. spot</td></tr> <tr><td>13. spot</td></tr> <tr><td>14. spot</td></tr> <tr><td>15. spot</td></tr> <tr><td>16. spot</td></tr> <tr><td>17. spot</td></tr> <tr><td>18. spot</td></tr> <tr><td>19. spot</td></tr> <tr><td>20. spot</td></tr> </table>	1. spot	2. spot	3. spot	4. spot	5. spot	6. spot	7. spot	8. spot	9. spot	10. spot	11. spot	12. spot	13. spot	14. spot	15. spot	16. spot	17. spot	18. spot	19. spot	20. spot
1 1/2" ANSI 150 psi welded .....	61																																																																											
2" ANSI 150 psi welded .....	62																																																																											
3" ANSI 150 psi welded .....	63																																																																											
4" ANSI 150 psi welded .....	64																																																																											
6" ANSI 150 psi welded .....	65																																																																											
8" ANSI 150 psi welded .....	66																																																																											
10" ANSI 150 psi welded .....	67																																																																											
1 1/2" ANSI 300 psi welded .....	71																																																																											
2" ANSI 300 psi welded .....	72																																																																											
3" ANSI 300 psi welded .....	73																																																																											
4" ANSI 300 psi welded .....	74																																																																											
6" ANSI 300 psi welded .....	75																																																																											
8" ANSI 300 psi welded .....	76																																																																											
10" ANSI 300 psi welded .....	77																																																																											
DN50 PN16 welded .....	81																																																																											
DN50 PN40 welded .....	82																																																																											
DN65 PN16 welded .....	83																																																																											
DN65 PN40 welded .....	84																																																																											
DN80 PN16 welded .....	85																																																																											
DN80 PN40 welded .....	86																																																																											
DN100 PN16 welded .....	87																																																																											
DN100 PN40 welded .....	88																																																																											
Other (special defined by customer) .....	00																																																																											
3 wire .....	3																																																																											
4 wire .....	4																																																																											
Common return .....	5																																																																											
Common return 50 ohm offset .....	6																																																																											
1. spot																																																																												
2. spot																																																																												
3. spot																																																																												
4. spot																																																																												
5. spot																																																																												
6. spot																																																																												
7. spot																																																																												
8. spot																																																																												
9. spot																																																																												
10. spot																																																																												
11. spot																																																																												
12. spot																																																																												
13. spot																																																																												
14. spot																																																																												
15. spot																																																																												
16. spot																																																																												
17. spot																																																																												
18. spot																																																																												
19. spot																																																																												
20. spot																																																																												

\*) **Spot limitations:**  
Sheath 1" - max. 16 spot with 4 wires  
Sheath 3/4" - max. 10 spot with 4 wires  
Sheath 3/4" - max. 14 spot with 3 wires

Recommended installation in welded thermowell, which should be filled with dry Argon gas.

If the sensor is used in pressurized tanks, it must be protected by a thermowell with ambient pressure inside.

Non adjustable welded flange.

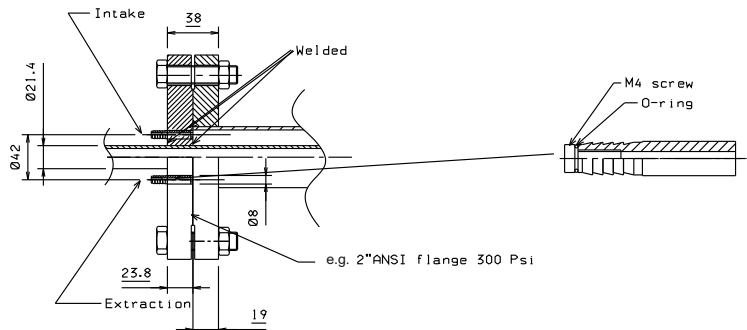

**Head office:**

Senmatic A/S  
 Industrivej 8, 5471 Sønderø, Denmark  
 Phone: +45 64 89 22 11  
 dk@senmatic.com - www.senmatic.com